

## VSH SmartPress

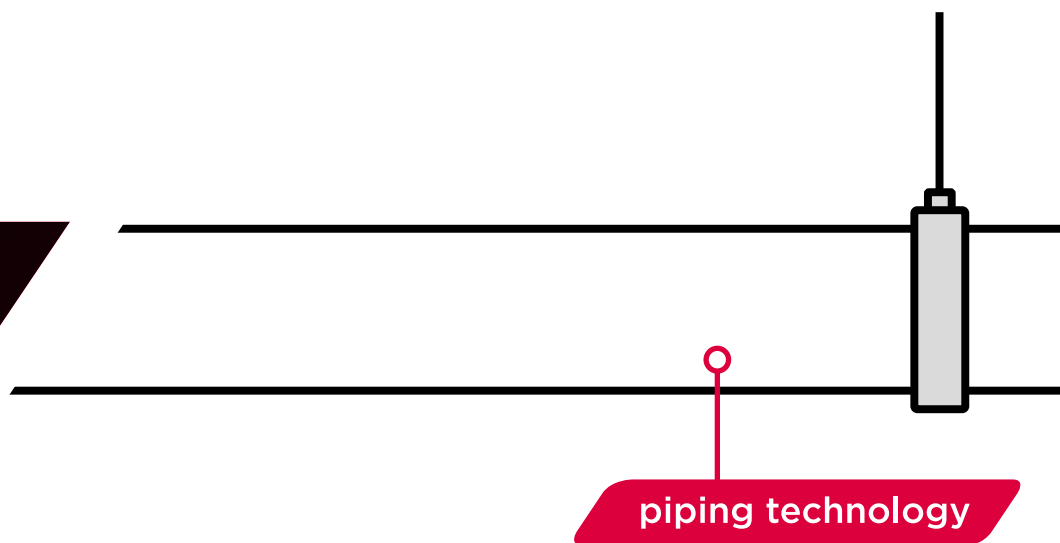

Aalberts integrated piping systems

don't just buy  
products,  
buy solutions.



# we are Aalberts integrated piping systems

Aalberts integrated piping systems engineers the most advanced integrated piping systems for the distribution and control of liquids and gases for key verticals, like industrial, utilities, commercial and residential. We offer fully integrated piping systems in valve, connection, fastening and piping technology. We work hand-in-hand with our customers to create the perfect integrated piping system, that meets their requirements. Our piping systems are easy to specify, install, control and maintain, saving important preparation and installation time. We meet the highest quality and industry standards needed in the selected verticals. We are the only business that truly offers its customers a single sourced and complete integrated piping solution, each and every time.

**Don't just buy products, buy solutions.**

## our mission

With our integrated piping systems, supported by the unique Digital Design Service, we ensure that you will always get the best and easiest solution for the installation of an integrated piping system. From the moment that your plan is being sketched out on the digital drawing board, you can get advice on complete and tailored solutions. With our Revit Plug-in you have digital access to the complete product offering within Aalberts integrated piping systems. This information is always accessible and up to date, allowing the design of an optimal and economically attractive installation that will meet all your demands. So whether the task is project conception, installation, or on-going maintenance, we are the company that truly delivers a complete system and service offering. Our know-how, our can-do attitude, and our relentless innovation come as standard. We will sweat the small stuff in our quest to find the perfect solutions, even if we have to invent them.

**This is how we deliver excellence.**

## our way of working

We operate from various regions around the globe: America, EMEA and APAC. As we have multiple locations in many countries, we are always close to our customers. More than 3500 mission critical employees are persistent to offer the best integrated piping system. They work on our products, solutions and services every day. No matter how big the opportunity is, when we say we've got this, we won't let go until there is nothing left to learn. We improve ourselves by exchanging knowledge and experience to stay ahead of our competitors.

**Good is never good enough.**

With our sustainable spirit we contribute to circularity every single day. This belief is strongly linked to the way we do business. Rethink, reduce and recycle. We are entrepreneurial and take ownership in everything we do. We are convinced that self-development and diversity is essential.

**The Aalberts way, winning with people.**

## the strength of Aalberts integrated piping systems

- the perfect solution for every project
- smart, fast and efficient installation
- valuable advice from the drawing board to delivery
- a very wide product range

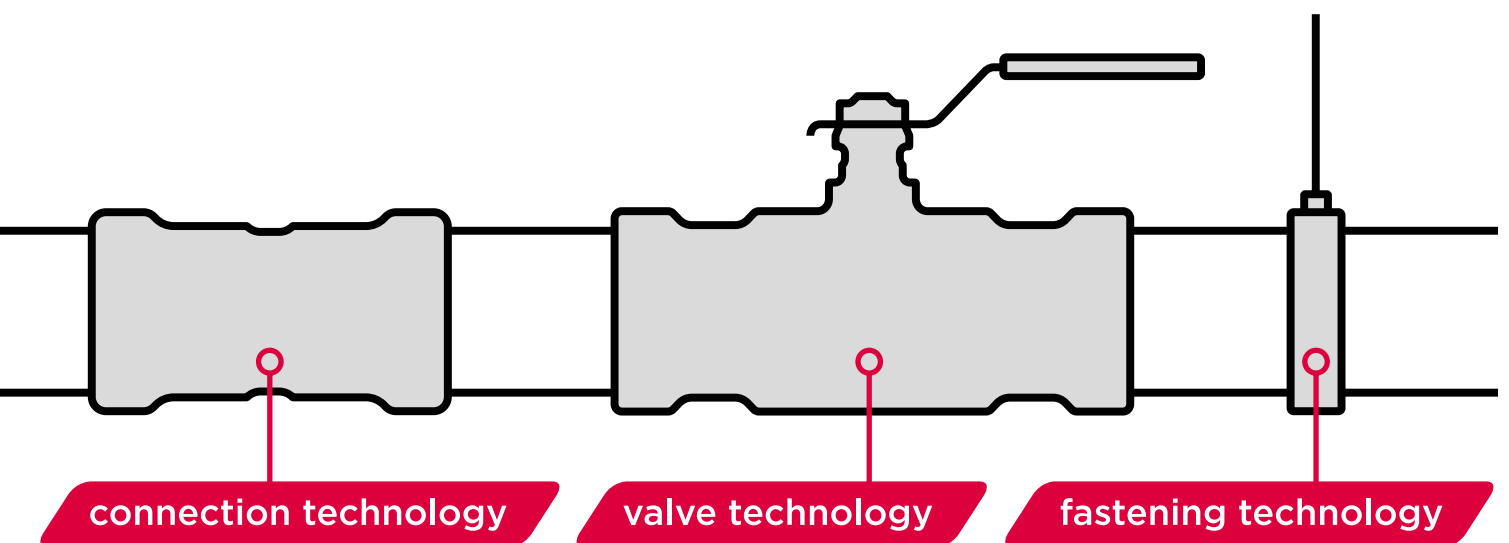

# Aalberts integrated piping systems connect: our systems are easy to combine with each other

Aalberts integrated piping systems is the combination of different companies with a strong legacy in their markets. The individual brands are well-known and each represents a long history. Together they offer the best integrated piping system for now and in the future.

## our product lines

We offer product ranges that:

- connect seamlessly
- are available in dimensions from 6 mm up to 104" (DN2600)
- can be used for thick-walled pipe and thin-walled metal or plastic tube
- have press, compression, groove and push connections
- can be expanded with valves and accessories
- are BIM ready

### Connection technology

#### VSH

VSH has been supplying quality products for 90 years and delivers piping systems and fittings throughout the world. In the 1970's VSH brought the well-known VSH Super compression fitting on the market which is still a best-seller, followed by the VSH XPress pressfitting, a technology that makes it possible to realize a connection even faster and more reliable.

#### Shurjoint

The history of Shurjoint dates back to 1974, when the founders produced their first grooved couplings. These first couplings were produced from malleable iron, the casting material of choice at this time. Shurjoint is recognized as a world leader in the design and manufacture of mechanical piping components.

### Valve technology

#### Apollo

Apollo Valves has been supplying the commercial and industrial valve markets since 1928. The valves, with their signature yellow handles, are designed and manufactured in their state-of-the-art facilities in the Carolinas, USA. Apollo's vertical manufacturing integration assures better quality control, better cost control, and the shortest delivery lead times possible for their range of ball valves, automation products, safety relief valves, backflow preventers and plumbing/heating products

### VSH SmartPress



material	stainless steel
suitable for	stainless steel (schedule 5S/10S)
connection	press / V-profile (ASP)
dimensions	½" - 2" (DN15 - DN50)

### VSH PowerPress®



material	carbon steel
suitable for	thick-walled steel
connection	press / DW-profile
dimensions	½" - 2" (DN15 - DN50)

### VSH SudoPress



material	carbon steel / stainless steel / copper
suitable for	carbon steel / stainless steel / copper
connection	press / V-profile
dimensions	12 - 108 mm (DN10 - DN100)

### Apollo Valves



material	brass / bronze / carbon steel / stainless steel
suitable for	steel / carbon steel / stainless steel / copper
connection	threaded / press / push / flange
dimensions	DN15 - DN300

### VSH Shurjoint



material	ductile iron / stainless steel
suitable for	thick-walled steel / stainless steel / HDPE
connection	groove
dimensions	½" - 104" (DN15 - DN2600)

### VSH Super



material	brass
suitable for	carbon steel / stainless steel / copper / plastic
connection	compression
dimensions	6 - 54 mm (DN4 - DN50)

### Seppelfricke



material	brass
suitable for	steel / carbon steel / stainless steel / copper
connection	press (V & M profile) / threaded
dimensions	10 - 54 mm (DN8 - DN50)

### Apollo ProFlow



material	brass / ductile iron
suitable for	carbon steel / stainless steel / copper / plastic
connection	threaded / press / flange
dimensions	DN15 - DN300

### VSH Tectite



material	copper / brass / stainless steel
suitable for	copper / carbon steel / stainless steel
connection	push
dimensions	10 - 54 mm (DN8 - DN50)

### VSH XPress



material	carbon steel / stainless steel / copper / unifer
suitable for	carbon steel / stainless steel / copper / unifer
connection	press / M-profile
dimensions	12 - 108 mm (DN10 - DN100)

### VSH UltraLine



material	PPSU / brass / PVDF
suitable for	plastic
connection	sliding sleeve
dimensions	14 - 32 mm (DN10 - DN25)

### VSH MultiPress



material	PPSU / brass
suitable for	plastic
connection	press / U & TH profile
dimensions	14 - 63 mm (DN10 - DN50)

# VSH SmartPress, the smartest press system for stainless piping

Ultra-modern manufacturing technology meets proven product design expertise with the all new VSH SmartPress fitting and valve product offering produced from AISI 316 stainless steel alloy. VSH SmartPress is an innovative IPS press connection system designed for joining ½” through 2” ASTM A312 stainless steel in combination with schedule 5S and 10S piping systems (type 304/304L or 316/316L). Whether you are installing a commercial potable water system or an industrial utilities process application, VSH SmartPress is made to withstand the harshest of environments.

## 3x safety assurance

All VSH SmartPress fittings and valves come equipped with VSH technology 3x safety assurance. These smart safety features reduce installation error, generate time cost savings and above all else, ensure job site safety.

### 1. visual materials identification

The color-coded Visu-Control® foil indicates the connection size and sealing element compound within the press fitting or valve to reduce the risk of misapplication – yellow indicates HNBR, green: EPDM, and blue: FPM.

### 2. visual press identification

The Visu-Control® foil splits for easy removal after press completion; this ensures that unpressed connections stand out and are easily recognizable prior to system pressurization.

### 3. mechanical press identification

Built-in Leak Before Pressed technology allows media to slowly leak for easy detection of unpressed connections during initial pressure testing.





#### smart sealing elements

All VSH SmartPress products feature a patented 'smart' sealing element with a unique geometry that provides a dual function grip, it allows for immediate tactile detection upon insertion while also keeping the fitting firmly in place on the pipe for optimal alignment and convenient installation. Additionally, VSH SmartPress' advanced sealing technology includes built-in Leak Before Pressed® technology and is manufactured and assembled using a silicone-free process.

convenient installation,  
time savings and safety are  
the top priorities

- one material, maximum efficiency (AISI 316)
- wide range of ½" through 2" fittings and valves
- up to 34 bar operating pressure
- temperatures ranging from -35°C to 230°C
- ultra-modern silicone-free production process
- patented 'smart' sealing element technology
- Leak Before Pressed technology
- Visu-Control® foil technology
- color-coded materials and size
- visual press indication
- patented pre-marked insertion depths







# VSH SmartPress application coverage

The VSH SmartPress product range consists of V-profile press fittings and valves fitted with patented sealing elements for a guaranteed safe, leak-tight and lasting connection.

The VSH SmartPress system offers a complete solution with maximum coverage of applications requiring HNBR, EPDM, or FPM sealing elements.

For each sealing element variation, available VSH SmartPress fitting configurations include: couplings, caps, elbows, thread adapters, tees, reducers, flange adapters and unions; VSH SmartPress valve configurations include the single-piece FullFlow ball valve.



## VSH SmartPress HNBR characteristics

- yellow Visu-Control® foil
- yellow bag & box labels
- yellow marked, black HNBR sealing elements (lubricant-free)

### temperature range

- -30°C to 100°C
- 110°C max (short-term)

### max. pressure

- 34 bar max for 10S
- 21 bar max for 5S

### most suitable for

potable water, fire sprinkler, heating & cooling, compressed air, hydrocarbons, instrument air, mineral & vegetable oil, engine & transmission oil, fuel oil, vacuum, circulation pipes, industrial gases.



## VSH SmartPress EPDM characteristics

- green Visu-Control® foil
- green bag & box labels
- black EPDM sealing elements (lubricant-free)

### temperature range

- -35°C to 135°C
- 150°C max (short-term)

### max. pressure

- 34 bar max for 10S
- 21 bar max for 5S

### most suitable for

potable water, fire sprinkler, heating & cooling, compressed air (synthetic or dry), instrument air, vacuum, circulation pipes, low pressure steam (max 110°C).



## VSH SmartPress FPM characteristics

- blue Visu-Control® foil
- blue bag & box labels
- blue FPM sealing elements (ozone-resistant)

### temperature range

- -20°C to 200°C
- 230°C max (short-term)

### max. pressure

- 34 bar max for 10S
- 21 bar max for 5S

### most suitable for

industrial design (ozone-resistant), solar installations, compressed air, lubricants, mineral & vegetable oil, fuel oil, industrial gases, hydrocarbons, vacuum.

# VSH SmartPress fittings

## prioritize safety, reduce error costs

one material, maximum efficiency (AISI 316)  
up to 34 bar operating pressure  
wide coverage of industrial and commercial applications  
patented HNBR, EPDM and FPM sealing elements  
silicone-free production process  
VSH technology 3x safety assurance:  
1. visual identification of material and size  
2. visual identification of unpressed connections  
3. mechanical identification of unpressed connections  
10-year limited warranty  
BIM ready

## clear laser marking

All fittings come laser etched with the brand logo, size, sealing element (H, E, F), traceability code, country of origin and applicable certifications.

## pre-marked insertion depths

Factory marked insertion depth line on street-end fittings save time and promote confident connections.

### floating flange options

VSH SmartPress Van Stone flange adapter's floating 2-piece design allows for easy bolt-hole alignment with stationary surfaces.



### ground-joint unions

Easily connect and disconnect where breaks in the system are needed with VSH SmartPress unions. Precisely machined metal-to-metal union seals eliminate loose parts and prevent misalignment.



### Visu-Control® foil

The color-coded VCF visual safety feature reduces the risk of misapplication (material, size) and provides breakaway press confirmation, ensuring unpressed connections stand out prior to system pressurization.

### Leak Before Pressed

The built-in LBP mechanical safety feature allows for easy identification of unpressed connections during initial pressure testing.



### smart sealing elements

Patented design provides tactile detection of sealing element presence, optimal pipe grip, and Leak Before Pressed functionality.

# VSH SmartPress FullFlow ball valve

## key features VSH SmartPress FullFlow ball valve

- 100% full port flow
- blow-out proof stem
- one material for maximum corrosion protection (stainless steel AISI 316)
- the high-precision VSH SmartPress press profile (V/ASM-profile) ensures fast, perfect connections
- color coded Visu-Control® foil technology indicates sealing element, size, and breakaway press confirmation
- Leak Before Pressed function allows unpressed connections to be quickly detected
- 5-year limited warranty
- BIM ready

### flushing ball

The flushing ball seal helps mitigate bacterial growth and balances the ball and cavity pressure, which is critical in freezing conditions to prevent damage.

### one system, one material

Using the same material throughout the installation will prevent any corrosion or contact corrosion problems.

### Leak Before Pressed

The Leak Before Pressed function allows unpressed connections to be quickly detected, reducing the risk of error costs.

### simple connection technology

The high-precision VSH SmartPress press profile (V/ASM-profile) ensures fast, perfect connections.

### patented design

The VSH SmartPress FullFlow ball valve is maintenance free and includes a patented spring construction for optimal ball sealing and a long life in harsh environments.

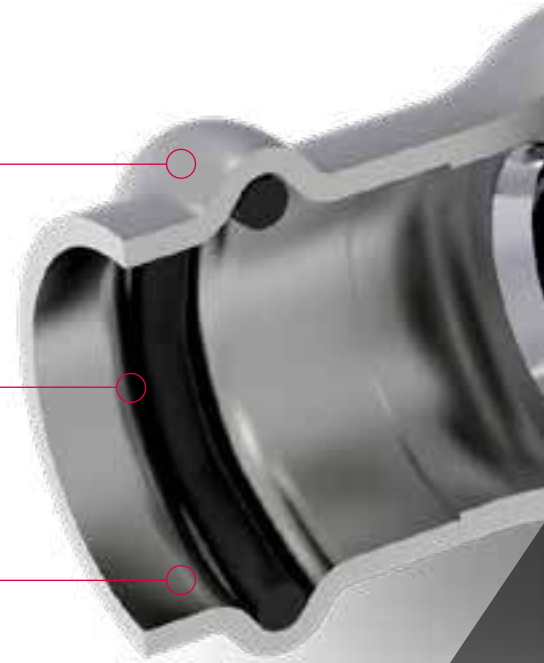



**smart handle inserts**

Reversible color-coded handle inserts make application identification simple and easy (red: hot, blue: cold).

**ergonomic handle**

Reversible stainless steel handle with composite outer-layer remains cool in high-temperature installations and can be easily mounted in either direction without using any tools.

**insulatable stem**

Optimal insulation possibilities because all VSH SmartPress FullFlow ball valves come with a stem guide that does not rotate when the valve is operated.

**convenient color coding**

Exterior colour coding avoids the use of incorrect material. Yellow indicates HNBR, green: EPDM and blue: FPM.

**compact FullFlow design**

Meet modern HVAC system requirements with the compact single-piece FullFlow design that makes for easy insulation work in tight spaces.

**clear laser marking**

Clear laser markings allows you to see all material and size information at a glance. VSH SmartPress FullFlow ball valves also have an unique identification number as standard and are 100% tested before leaving the factory.



potable water



heating



cooling



compressed air



steam



solar



sprinkler



vacuum

# VSH SmartPress general applications

## potable water

With a VSH SmartPress system, you can be confident of compliance with all applicable standards for open and closed water and potable water systems. All system components are available in stainless steel and are fully corrosion resistant, even when exposed to demineralised or distilled water.

## heating and cooling

VSH SmartPress is the best solution for heating and cooling systems. The products undergo the most stringent tests during the production process and are absolutely leak-proof. Thanks to their design and the production process, the fittings have smooth interior profiles. As a result, they have very low flow resistance and low noise level. Additionally, the sleek and low-profile design of VSH SmartPress fittings and valves make insulation work seamless and easy.

## steam

VSH SmartPress Stainless is particularly suitable for low-pressure steam piping systems. Steam up to 110°C can even be installed with VSH SmartPress Stainless using the standard EPDM sealing element.

## compressed air

VSH SmartPress is ideal for compressed air installations. Different types of sealing elements are used depending on the oil content. When the compressed air contains mineral or vegetable oil, HNBR or FPM sealing elements must be used. EPDM sealing elements can only be used for synthetic oil or dry compressed air.

## solar

The VSH SmartPress system is equipped with EPDM sealing elements that can withstand high temperatures up to 135°C with allowable short-term spikes up to 150°C. If even higher temperatures are involved, choose VSH SmartPress products with special FPM sealing elements that can withstand temperatures up to 200°C with allowable short-term spikes up to 230°C.

## sprinkler

Our VSH SmartPress system is certified for sprinkler and low pressure water mist installations and is suitable for fixed sprinkler installations.

Application approval dependent on suitability of selected sealing element's performance characteristics and limitations. For more information on VSH SmartPress approved applications, please refer to our technical documentation listed at [aalberts-ips.eu/smartpress](http://aalberts-ips.eu/smartpress)

# are you facing these challenges with your projects?

- increased material and labor costs
- material estimating for future projects
- pipng interferences and trade collisions
- material back-orders
- compressed delivery schedules
- long lead-times
- space limitations
- unnecessary material waste



## Aalberts ips design service

To accompany our vast portfolio of piping products, we offer Aalberts ips design service to ensure an efficient build from start to finish because we understand that every project presents its own unique set of requirements and challenges. Our method is simple: using your concept plan, we will look for the most optimal and economic way to achieve your project requirements. That plan is then adjusted until you, and your client, are completely satisfied.



## Aalberts ips Revit plug-in

with this Autodesk Revit plug-in for, users can easily and clearly select Revit families and load them into projects. In addition to a library function, the plugin contains a number of useful tools that simplify the modeling of piping systems within Autodesk Revit.

- design complex piping systems faster with 15,000+ Aalberts ips products
- structured data based on ETIM-MC standards
- optimized piping systems and routing preferences based on application, approval, and standards
- modeling tools that simplify workflow and increase productivity
- compatible with latest Autodesk Revit versions (2019 through current)

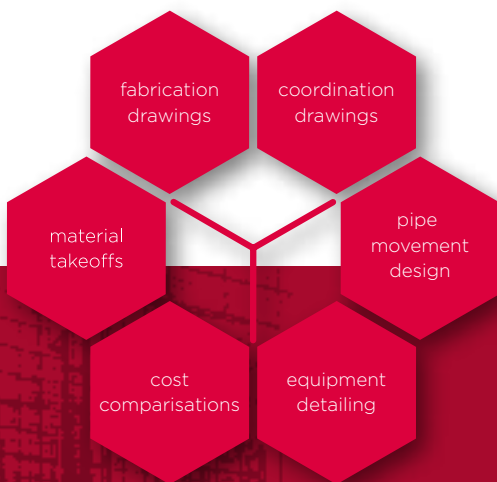

## Aalberts ips design service

### advantages

- detailed material takeoffs
- competitive cost comparisons
- custom equipment detailing
- 3D coordination drawings
- pipe movement design
- system fabrication drawings
- efficient design-build with Aalberts ips Revit plug-in

### coordination drawings

- 3D shop drawings for optimized coordination
- identify building interferences and trade conflicts
- get an early start with our preliminary materials lists to ensure accurate lead-times for on-time delivery of products

### pipe movement design

- thermal movement calculations
- identifying pipe anchor and guide locations with load calculations
- custom thermal expansion and seismic joints

### equipment detailing

- equipment drawings and material lists detailed using Aalberts ips products
- custom CAD/BIM model equipment connection detail
- installation assembly schematics

### cost comparisons

- compare Aalberts ips products against alternative piping methods
- evaluate competitive materials cost, labor cost and installation times

### material takeoffs

- itemized lists of Aalberts ips fittings, valves and piping accessories for projects
- includes project labor and materials estimates for system design

### fabrication drawings

- 3D MER tagged fabrication Formatting
- fitting and valve accessory BOMs
- piping spool lists

more information?

---

For a complete and up-to-date product range and our additional services, visit: [www.aalberts-ips.eu](http://www.aalberts-ips.eu)

Would you like to make an appointment to meet an account manager in your region or receive advice and support from one of our experts?

Please contact:

**Aalberts integrated piping systems Customer Service**

**+31 (0)35 68 84 330**

**[salesupport.emea@aalberts-ips.com](mailto:salesupport.emea@aalberts-ips.com)**

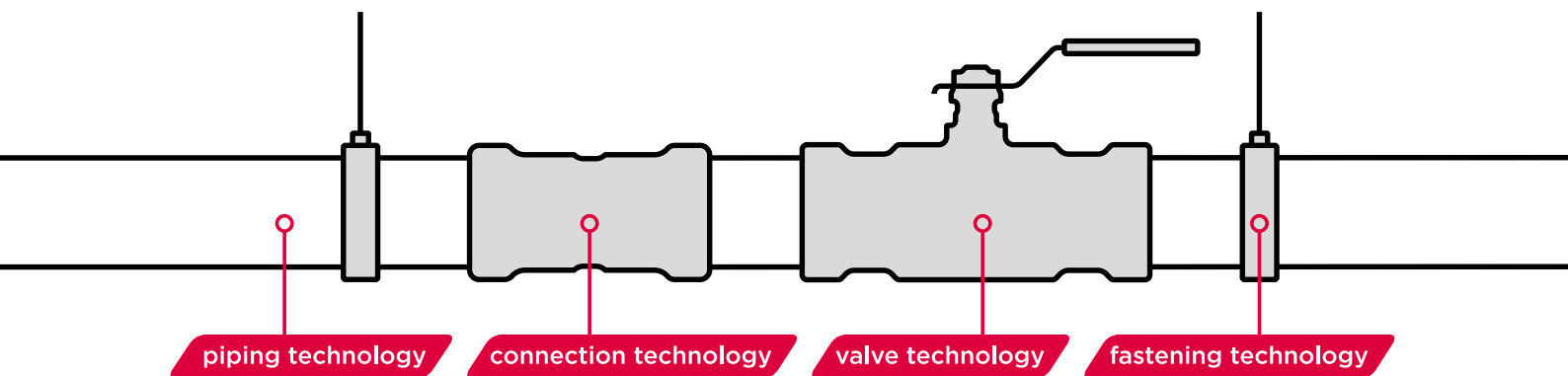

**Aalberts integrated piping systems B.V.**

Oude Amersfoortseweg 99 / 1212 AA Hilversum

P.O. Box 498 / 1200 AL Hilversum

The Netherlands

[www.aalberts-ips.eu](http://www.aalberts-ips.eu)